

CoCreate® Finite Element Analysis

Simulate real-world stresses on your design

CoCreate Finite Element Analysis offers an extensive set of finite element analysis (FEA) capabilities for engineers and designers.

Based on MSC Software Corporation's Nastran® and Patran® solutions, CoCreate Finite Element Analysis gives you all the power you need to simulate real-life mechanical and thermal stresses on products, directly within the CoCreate Modeling™ 3D CAD system.

Faster identification and resolution of design issues helps companies transition from a stage-gate process for design and analysis to a more efficient product development process, where digital simulation occurs as part of the daily design activity.

Easily perform a variety of FEA studies for structural, buckling, thermal, and frequency analysis, using various working load and boundary conditions that you apply to your product design.

Key Benefits

- Achieve faster realization of optimal designs, avoid both failure-prone and over-engineered components, and reduce physical prototyping costs.
- Identify areas within a product that will be prone to failure. Issues can be resolved early in the design process, increasing design quality, and saving costs and time.
- Conduct extensive trade-off studies upfront in the development process, and yield downstream benefits, including increased design quality, reduced time-to-market, reduced cost of goods sold, and reduced warranty exposure.

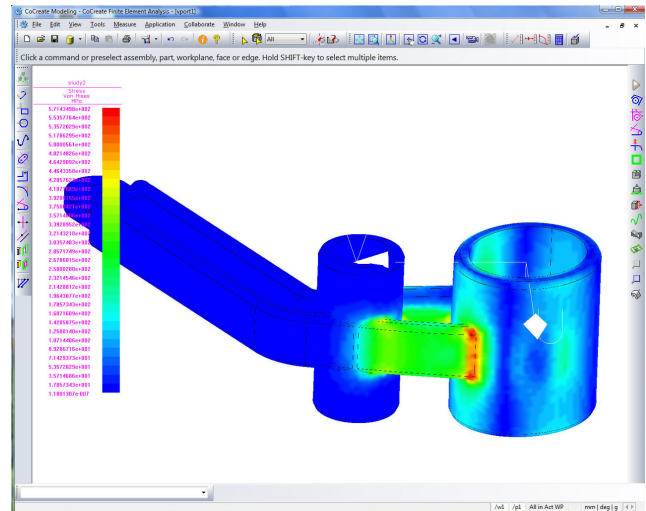

Run CoCreate Finite Element Analysis simulations on your virtual product model.

Features and Specifications

Complete and Fully Integrated Solution

- Perform linear and static analyses
- Execute all analyses within the CoCreate Modeling environment
- Set up and store loads and boundary conditions, and assign material types directly with the part or assembly data
- Store multiple studies of the same part or assembly data
- Leverage automatic meshing and solving for parts and assemblies
- Full-color visualization of part, clearly showing stress, strain, displacement, etc.
- Store results with the part
- Animate results and document using HTML

Analysis Cases

- Analyze stress levels, displacements, and resonant frequencies of designs. Supported cases include:
 - Linear static structural analysis
 - Linear buckling
 - Normal modes
- Analyze thermal cases:
 - Steady state thermal
 - Solving for temperature and flux

Loads and Boundary Conditions (LBCs)

- Assign LBCs directly to part or assembly, including:
 - Vertex, edges, and face loads
 - Spin, gravity, acceleration, and part temperature
 - Face pressure loads
 - Translational constraints and enforced displacements (XYZ) for vertex, edge, or face
 - Heat flow, heat generation, free convection, fixed temperature

Materials

- Leverage the standard database, which includes over 900 commonly used materials, such as multiple types of steel, aluminum, and plastics
- Add more materials and material parameters

Meshing

- Generate volumetric meshes automatically, using technology provided by MSC Software Corporation
 - Tetrahedral linear or quadratic order adaptive h-element technology
 - P-element technology
- Automatically create shell-elements tailored for sheet metal part analysis
- Generate surface mesh with triangular or quadratic h-elements
- Export mesh with or without LBC data as a PATRAN-neutral file
- Apply mesh conditions to the part or assembly, and control local mesh density

Solving

- Solve cases with unlimited nodes and unlimited mesh size. Solving based on the latest h- and p-elements technology from industry-leader MSC Software Corporation

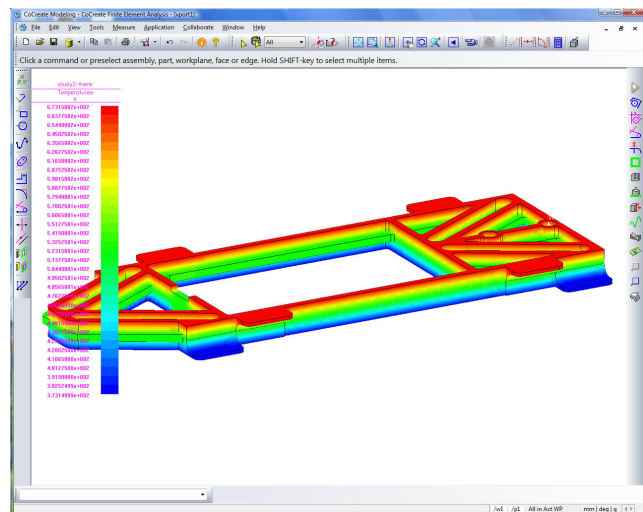

Easily detect weaknesses in your design before performing expensive tests on physical prototypes.

Prerequisites

- CoCreate Modeling

Platform Requirements

CoCreate Finite Element Analysis-supported operating systems:

- Windows® 7 32-bit and 64-bit Editions of Ultimate, Enterprise, and Professional
- Windows Vista® 32-bit and 64-bit Editions of Ultimate, Enterprise, and Business
- Windows XP Professional 32-bit and 64-bit Editions

For the most up-to-date platform support information visit: www.ptc.com/partners/hardware/current/support.htm

For more information, visit www.ptc.com/products/cocreate